



Steckverschraubungen aus Edelstahl





Steckverschraubungen aus Edelstahl

Lösering aus Edelstahl AISI 316(1.4401)

Führungsring Edelstahl AISI 316(1.4401)

Spannzange aus Edelstahl AISI 301
stainless clamp
Pinza in acciaio inox.
Pince en acier inox.

Stützring Edelstahl AISI 316(1.4401)

Gehäuse aus Edelstahl AISI 316(1.4401)

O-Ringe aus Viton
Viton O-Ring
O-R in Viton
Bague O R en Viton

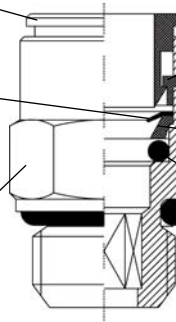

Technische Daten für Steckverschraubungen Serie STX

Toleranz für Polyamid-Schlauch PA11/12

Rohr-Außen-Ø	Toleranz des Außen-Ø	
4 - 8mm	+0,1	-0,1
10 - 22mm	+0,15	-0,15

Toleranz für Polyamid-Schlauch PU

Rohr-Außen-Ø	Toleranz des Außen-Ø	
4 - 8mm	+0,1	-0,1
10 - 14mm	+0,15	-0,1

Technische Daten:

- Betriebstemperatur : -20°C +150°C
- geeignete Medien : Druckluft, alle flüssigen und gasförmigen Medien, die mit den Werkstoffen der Komponenten kompatibel sind.
- Vakuum : max.98%
- Werkstoff : Gehäuse aus Edelstahl AISI 316(1.4401)
: Dichtungen aus Viton
: Spannzange aus Edelstahl AISI 301
: Druckring aus Edelstahl
- Gewinde : zylindrisch BSPP mit O-Ringabdichtung Viton
- Anwendungsgebiete : für alle flüssigen und gasförmigen Medien, die mit diesen Bestandteilen kompatibel sind, z.B. Kalt- und Warmwasser, Dampf, Fette und Öle, Industrieabwässer. Für Vakuum geeignet.



Technical data for push-in fittings in the STX-Series

Tolerances for PA11 and PA12 pipes (Polyamide)

Outside pipe diameter	Outside pipe diameter tolerance	
4 - 8mm	+0,1	-0,1
10 - 22mm	+0,15	-0,15

Tolerances for Polyurethane (PU) pipes

Outside pipe diameter	Outside pipe diameter tolerance	
4 - 8mm	+0,1	-0,1
10 - 14mm	+0,15	-0,1

Technical data:

- Working temperature : -20°C +150°C
- Fluid : Compressed air (other fluids on request)
- Vakuum : max.98%
- Material : stainless steel AISI 316(1.4401)
: Silicone-free Viton gaskets
: AISI 301 stainless steel clamp
: AISI 316(1.4401) stainless steel Ring
- Threading : parallel BSPP with O-Ring Viton seal
- Fields of application : for all liquid and gas media, which are compatible with the various fitting components i.e.: cold + hot water, steam, greases and oils industrial liquids. Vacuum-compatible.

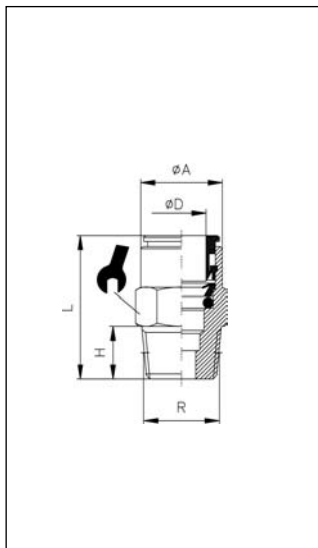

STX 11

gerade Einschraubverschraubung kon.

Straight male adaptor con.

Diritto filetto conico maschio

Piquage droit mâle

	ØD	G	ØA	H	L		
110418	4	R ¹ / ₈	9	7,5	15,5	10	50
110414	4	R ¹ / ₄	9	11,0	20,0	14	50
110618	6	R ¹ / ₈	12	7,5	20,5	12	50
110614	6	R ¹ / ₄	12	11,0	20,0	14	50
110818	8	R ¹ / ₈	14	7,5	24,5	14	50
110814	8	R ¹ / ₄	14	11,0	23,0	14	50
111014	10	R ¹ / ₄	16	11,0	30,0	16	50
111038	10	R ³ / ₈	16	11,5	23,5	17	50
111238	12	R ³ / ₈	18	11,5	27,0	18	50
111212	12	R ¹ / ₂	18	14,0	27,0	27	50

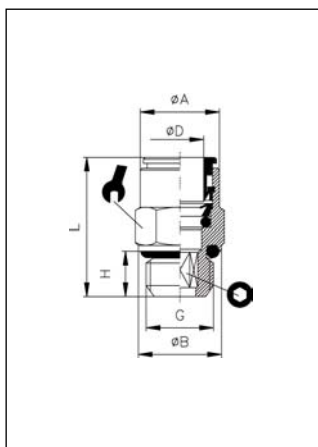

STX 12

gerade Einschraubverschraubung zyl.

Straight male adaptor (parallel)

Diritto filetto cilindrico maschio con O-Ring

Piquage droit mâle cylindrique

	ØD	G	ØA	ØB	H	L			
120405	4	M5	9	8	4,0	19,	-	9	10
120418	4	G ¹ / ₈	9	13	5,0	16,0	3	13	10
120618	6	G ¹ / ₈	12	13	5,0	19,0	4	13	10
120614	6	G ¹ / ₄	12	16	6,5	18,5	4	16	10
120818	8	G ¹ / ₈	14	13	5,0	22,5	6	14	10
120814	8	G ¹ / ₄	14	16	6,5	21,0	6	16	10

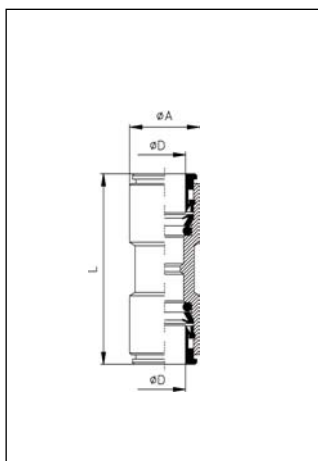

STX 26

gerader Verbinder

Straight connector

Intermedio

Union double

	ØD	ØA	L	
260404	4	9	27,0	10
260606	6	9	32,5	10
260808	8	12	33,0	10
261010	10	12	37,5	10
261212	12	14	39,5	10

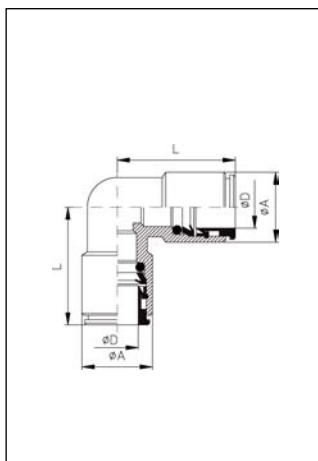

STX 28

Winkelverbinder

Elbow connector

Gomito innestabile

Equerre égale

	ØD	ØA	L	
280404	4	9	17,0	10
280606	6	9	20,0	10
280808	8	12	21,0	10
281010	10	12	25,0	10
281212	12	14	27,0	10

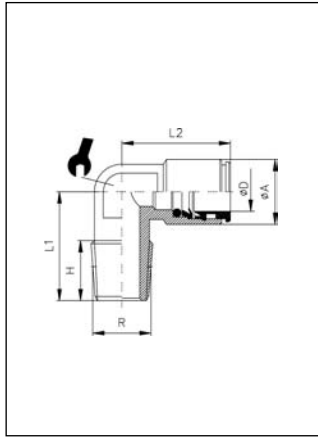

STX 14

Winkeleinschraubverschraubung konisch

Elbow taper male adaptor con.

Raccordo ad L maschio conico

Équerre mâle conique

	ØD	R	ØA	H	L1	L2		
140418	4	R ¹ / ₈	9	7,5	16,0	17,0	9	10
140618	6	R ¹ / ₈	12	7,5	16,0	20,0	9	10
140614	6	R ¹ / ₄	12	11,0	20,0	20,0	11	10
140818	8	R ¹ / ₈	14	7,5	17,0	21,0	11	10
140814	8	R ¹ / ₄	14	11,0	20,0	21,0	11	10

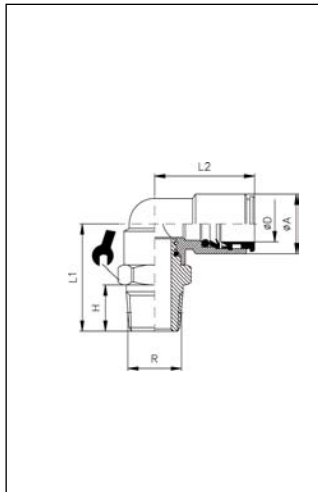

STX 15

Winkeleinschraubverschraubung konisch

Swivel elbow adaptor

Raccordo ad L girevole conico

Équerre mâle orientable conique

	ØD	R	ØA	H	L1	L2		
150418	4	R ¹ / ₈	9	7,5	17,5	17,0	10	10
150618	6	R ¹ / ₈	12	7,5	20,0	21,5	13	10
150614	6	R ¹ / ₄	12	11,0	24,0	21,5	14	10
150818	8	R ¹ / ₈	14	7,5	20,0	22,0	13	10
150814	8	R ¹ / ₄	14	11,0	24,0	22,0	14	10
151014	10	R ¹ / ₄	16	11,0	26,5	25,5	16	10
151038	10	R ³ / ₈	16	11,5	27,0	25,5	17	10
151238	12	R ³ / ₈	18	11,5	30,5	28,0	20	10
151212	12	R ¹ / ₂	18	14,0	33,5	28,0	22	10

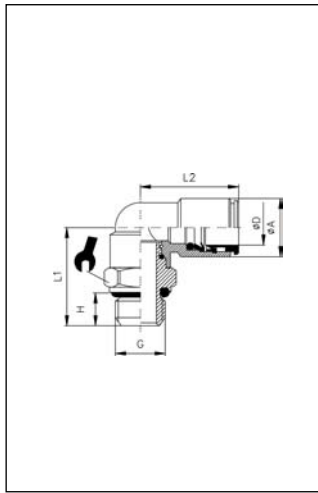

STX 16

Winkeleinschraubverschraubung zylindrisch

Swivel elbow parallel adaptor

Raccordo ad L girevole cilindrico

Équerre mâle orientable cylindrique

	ØD	G	ØA	H	L1	L2		
160405	4	M5	9	4,0	14,0	17,0	9	10
160418	6	G ¹ / ₈	9	5,0	16,0	17,0	13	10
160618	6	G ¹ / ₈	12	5,0	18,0	21,5	13	10
160614	8	G ¹ / ₄	12	6,5	20,0	21,5	16	10
160818	8	G ¹ / ₈	14	5,0	18,0	22,0	13	10
160814	10	G ¹ / ₄	14	6,5	20,0	22,0	16	10

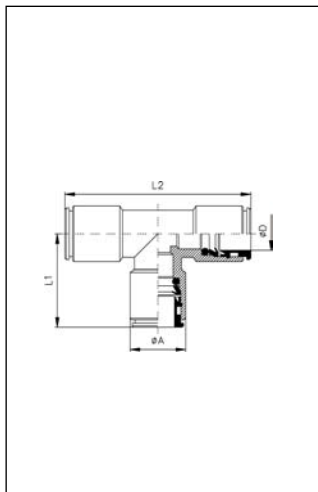

STX 29

T-Verbinder

Tee connector

T innestabile

Té égal

	ØD	ØA	L1	L2	
290404	4	9	17	34	10
290606	6	9	20	40	10
290808	6	12	21	42	10
291010	8	12	25	50	10
291212	8	14	27	54	10

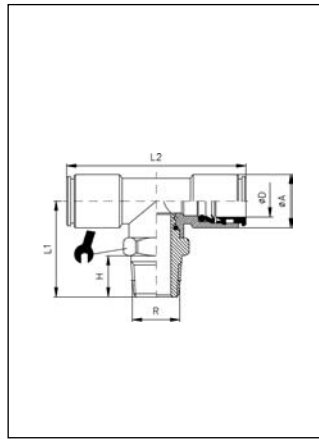

STX 20

T-Verschraubung drehbar konisch

Swivel tee adaptor con.

Raccordo a T girevole con.

Té centre mâle orientable con.

	ØD	R	ØA	H	L1	L2		
200418	4	R ¹ / ₈	9	7,5	21,5	34,0	10	10
206018	6	R ¹ / ₈	12	7,5	24,5	42,0	13	10
206014	6	R ¹ / ₄	12	11,0	28,5	42,0	14	10
200818	8	R ¹ / ₈	14	7,5	24,5	43,0	13	10
208014	8	R ¹ / ₄	14	11,0	28,5	43,0	14	10
201014	10	R ¹ / ₄	16	11,0	32,0	50,0	16	10
201038	10	R ³ / ₈	16	11,5	32,5	50,0	18	10

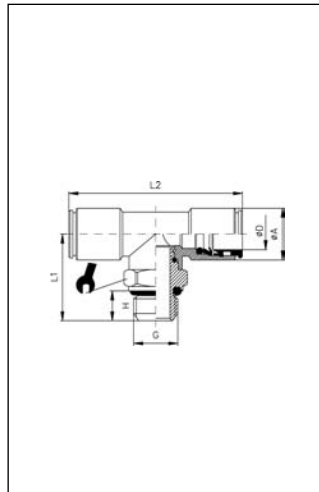

STX 21

T-Verschraubung drehbar zylindrisch

Swivel tee parallel adaptor

Raccordo a T girevole

Té centre mâle orientable

	ØD	R	ØA	H	L1	L2		
210405	4	M5	9	4,0	18,0	34,0	9	10
210418	6	G ¹ / ₈	9	5,0	20,0	34,0	13	10
210618	6	G ¹ / ₈	12	5,0	22,5	42,0	13	10
210614	8	G ¹ / ₄	12	6,5	24,5	42,0	16	10
210818	8	G ¹ / ₈	14	5,0	22,5	43,0	13	10
210814	10	G ¹ / ₄	14	6,5	24,5	43,0	16	10

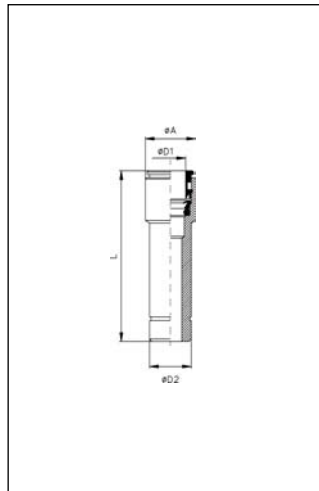

STX 25

Reduzier-Stecker

Reducer

Riduzione

Réduction

	ØD1	ØD2	ØA	L	
250406	4	6	9	31,0	10
250608	6	8	12	33,0	10
250810	8	10	14	34,5	10

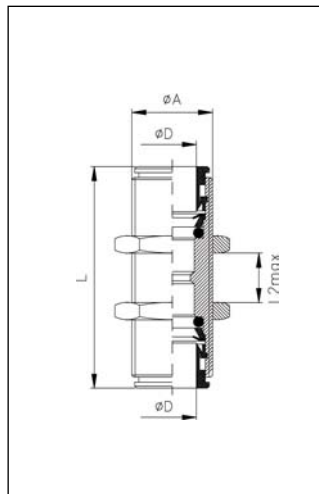

STX 27

Schottverschraubung

Stainless steel Bulkhead

Passaparete Inox

Traversé de cloison en Inox

	ØD	M	L1	L2max.		
270404	4	M12x1	27,0	11	15	10
270606	6	M14x1	32,5	16	17	10
270808	8	M16x1	33,5	17	19	10
271010	10	M18x1	37,5	19	21	10
271212	12	M20x1	39,5	20	24	10

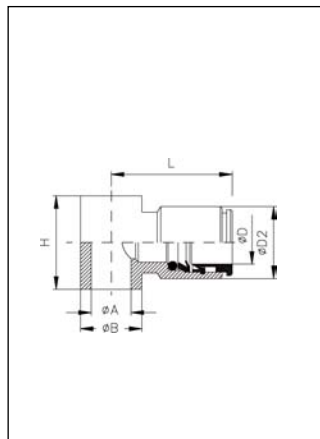

STX 35

Ringstück

Single banjo body

Anello singolo

Corps de banjo simple

	ØD	ØA	ØD2	ØB	L	H		
350418	4	G ^{1/8}	9	14	19,5	15		10
350618	6	G ^{1/8}	12	14	22,0	15		10
350614	6	G ^{1/4}	12	18	23,5	17		10
350818	8	G ^{1/8}	14	14	22,5	15		10
350814	8	G ^{1/4}	14	18	24,0	17		10

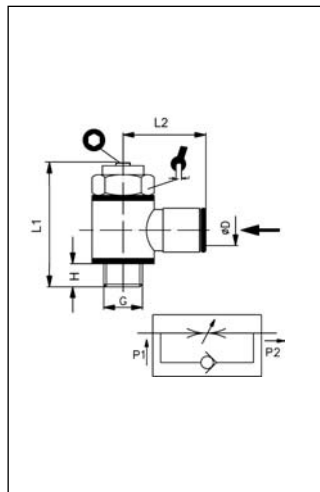

STX 40

Drosselrückschlagventil mit Ringstück

Typ A Zuluft drosselbar

Undirectional flow regulator type A for valves

Regolatore di flusso unidirezionale per valvole tipo A

Régulateur de alimentation d'une seule direction pour valves type A

	ØD	G	H	L1max	L2		Ø	
400418	4	G ^{1/8}	5,5	36	19,5	14	2,5	10
400618	6	G ^{1/8}	5,5	36	21,5	14	2,5	10
400818	6	G ^{1/8}	5,5	36	23,5	14	2,5	10
400614	8	G ^{1/4}	6,5	42	23,5	17	3	10
400814	8	G ^{1/4}	6,5	42	24,0	17	3	10

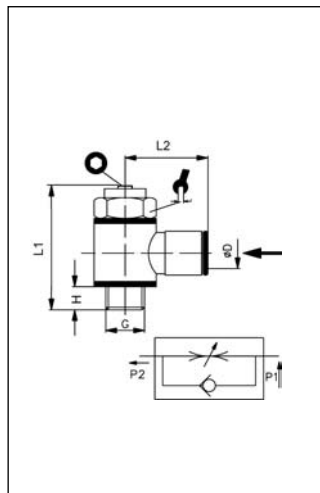

STX 41

Drosselrückschlagventil mit Ringstück

Typ B Abluft drosselbar

Undirectional flow regulator type B for cylinders

Regolatore di flusso unidirezionale per cilindri tipo B

Régulateur de alimentation d'une seule direction pour vérins type B

	ØD	G	H	L1max	L2		Ø	
410418	4	G ^{1/8}	5,5	36	19,5	14	2,5	10
410618	6	G ^{1/8}	5,5	36	21,5	14	2,5	10
410818	6	G ^{1/8}	5,5	36	23,5	14	2,5	10
410614	8	G ^{1/4}	6,5	42	23,5	17	3	10
410814	8	G ^{1/4}	6,5	42	24,0	17	3	10

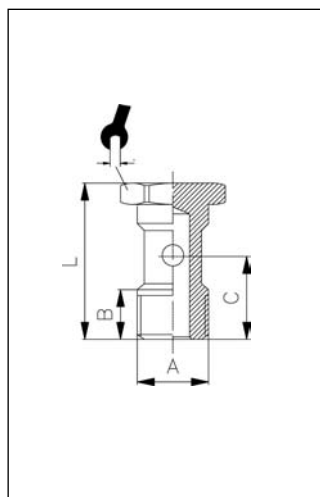

STX 31

Hohlschraube 1-fach, inkl. 2x Teflon-Dichtungen

Banjo stem single short, incl. 2x Teflon-seals

Vite cava semplice, con 2x Teflon-guarnizione

Vis un étage creuse, avec 2x Téflon joints

	A	B	C	L		
310018	G ^{1/8}	9,0	15,0	29,0		14 50
310014	G ^{1/4}	9,3	17,5	32,5		17 50